

# George Foreman

Lean Mean Grilling Machine

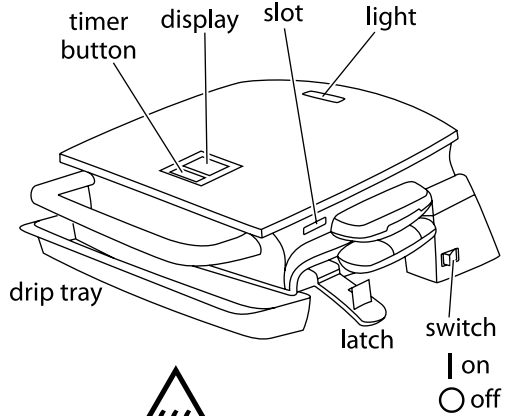

**instructions and  
recipes**

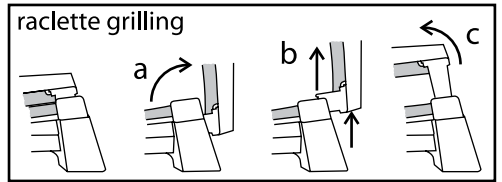
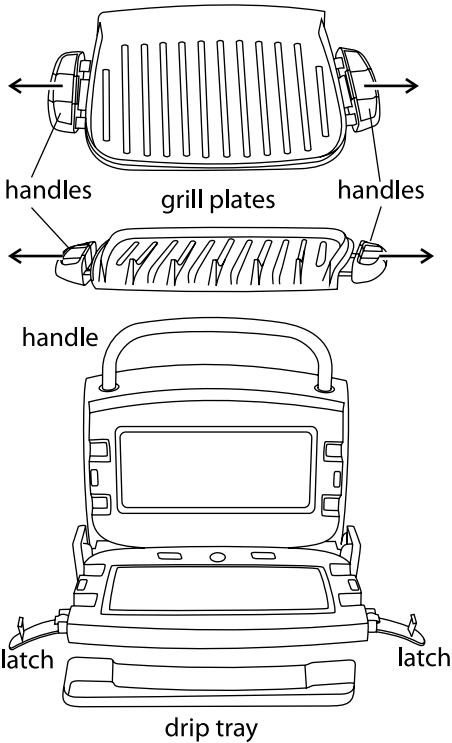

Read the instructions and keep them safe. Pass them on if you pass the grill on. Remove all packaging, but keep it till you know the grill works.

### important safeguards

Follow basic safety precautions, including:

- 1 The grill must only be used by or under the supervision of a responsible adult. Use and store it out of reach of children.
- 2 Don't put the grill in liquid, don't use it in a bathroom, near water, or outdoors.
- 3 Don't use the grill unless the grill plates are fitted.
- 4 Some parts aren't as hot as others, but they're all hot. Don't touch – use oven gloves or a folded towel.
- 5 Bread, oil, and other foods may burn. Don't use the appliance near or below curtains or other combustible materials, and watch it while in use.
- 6 Sit the grill on a stable, level, heat-resistant surface, near a power socket.
- 7 Route the cable so it doesn't overhang, and can't be tripped over or caught.
- 8 Don't use the grill with an external timer or remote control system.
- 9 Don't wrap food in plastic film, polythene bags, or metal foil. You'll damage the grill and you may cause a fire hazard.
- 10 Cook meat, poultry, and derivatives (mince, burgers, etc.) till the juices run clear. Cook fish till the flesh is opaque throughout.



- 11 Keep the grill and cable away from hotplates, hobs or burners.
- 12 Unplug the grill after use, before moving and before cleaning.
- 13 Don't use the grill for any purpose other than cooking food.
- 14 Don't use the grill if it's damaged or malfunctions.
- 15 If the cable is damaged, return the grill, to avoid hazard.

## **household use only**

### **before using for the first time**

Turn to "care and maintenance" on page 4, and clean the grill, to remove any dust left by the manufacturing processes.

### **preparation**

- 1 Centre the drip tray under the front of the grill, to catch run-off.
- 2 Grip the tops of the latches, and pull them out of their slots, to unlock the grill.
- 3 Open the grill, wipe the grill plates with a little cooking oil or butter, then close the grill. Don't use low fat spread – it may burn on to the grill.

### **preheat**

- 4 Put the plug into the power socket (switch the socket on, if it's switchable).
- 5 Move the switch to | to turn the grill on – the display will show 277.
- 6 The light will come on, then cycle on and off as the thermostat operates to maintain the temperature. When the light goes off, the grill is ready for use.

### **fill the grill**

- 7 When the light goes off, use an oven glove to open the grill.
- 8 Lay the food on the bottom grill plate with a spatula or tongs, not fingers.
- 9 Don't use anything metal or sharp, you'll damage the non-stick surfaces.

### **contact grilling**

- 10 Simply bring the handle forward, to close the grill on the food.
- 11 The hinge is articulated to cope with thick or oddly shaped foods.
- 12 The grill plates should be roughly parallel, to avoid uneven cooking.
- 13 Contact grilling tends to be faster, as both grill plates are in contact with the food.

### **raclette grilling**

- 14 Follow the drawing at the top left of page 2 (raclette grilling):
  - a) open the grill
  - b) lift the lid straight up, to bring the hinges to the top of their travel
  - c) pull the lid forward as you close it, leaving a gap between the grill plates
- 15 Raclette grilling tends to be a bit slower, as the upper grill plate is clear of the food, but it has the advantage that you can grill things you don't want to squash, like cheese on toast, or tomatoes.

### **check that the food is cooked**

- 16 Whichever cooking method you use, check that the food is cooked through before serving.
- 17 If you're in doubt, cook it a bit more.
- 18 Cook meat, poultry, and any derivatives (mince, burgers, etc.) till the juices run clear. Cook fish till the flesh is opaque throughout.

## **remove the food**

19 Use the oven glove to open the grill.

20 Use wooden or plastic tools to remove the food.

## **finished?**

21 Switch off (○) and unplug the grill.

## **more?**

22 Put on the oven glove, empty the drip tray into a heatproof bowl, then give it a wipe with kitchen paper, and put it under the front of the grill.

## **using the timer**

23 Using the timer is optional. It doesn't switch the elements off or interfere with the cooking process, it simply beeps to let you know that the time you set has expired.

24 Use the timer button to set the time on the display to the time you want.

25 The range is from 0 to 20 minutes.

26 The timer will count down, beep 4 times, then the display will revert to 00.

★ 00 means exactly that – if you leave food on the grill, it'll keep on cooking.

## **care and maintenance**

1 Unplug the grill and let it cool before cleaning or storing away.

2 Open the grill.

3 Remove one grill plate at a time.

4 Grip the handles at the sides of the grill plate.

5 Slide the surfaces marked "RELEASE" outwards, to unlock the grill plate

6 Lift the grill plate off the grill.

7 Now remove the other grill plate the same way.

8 After removal, wash the grill plates in warm soapy water, or in a dishwasher.

9 Dry the grill plates before replacing them on the grill.

10 Wash the drip tray in warm soapy water, or in the top rack of the dishwasher.

11 Wipe all other surfaces of the grill with a clean damp cloth.

12 Use a piece of paper towel and a little cooking oil to remove stubborn stains.

13 Replace one grill plate at a time.

14 Grip the handles at the sides of the grill plate.

15 Slide the surfaces marked "RELEASE" outwards, and hold them there.

16 Replace the grill plate on the grill.

17 Release the handles, to lock the grill plate in place.

18 Now replace the other grill plate the same way.

19 If you close the grill, and push the latches into the slots, it can be stored upright, to save space.

20 Don't put the grill in water or any other liquid.

21 Don't use harsh or abrasive cleaners, solvents, scourers, wire wool, or soap pads.

★ Where the top and bottom plates make contact, the non-stick surfaces may show signs of wear. This is purely cosmetic, and won't affect the operation of the grill.

## cooking times & food safety

Use these times purely as a guide. They're for contact grilling fresh or fully defrosted food. When cooking frozen foods, add 2-3 minutes for seafood, and 3-6 minutes for meat and poultry, depending on the thickness and density of the food.

Check food is cooked through before serving. If in doubt, cook it a bit more.

Cook meat, poultry, and any derivatives (mince, burgers, etc.) till the juices run clear.

Cook fish till the flesh is opaque throughout.

When cooking pre-packed foods, follow any guidelines on the package or label.

	min		min
<b>beef</b>		<b>lamb</b>	
fillet	5-7	kebabs, 25mm cube	7-8
loin steak	7-8	minced	6-7
burger, 50g, fresh	5-6	loin chops	4-6
burger, 100g, fresh	7-8	<b>toasted sandwiches</b>	
burger, 200g, fresh	8-9	cheese	2-3
kebabs, 25mm cube	7-8	ham (cooked)	5-6
round steak	5-7	roast beef (cooked)	6-7
sausages (thin)	5-6	sausage (cooked)	6-7
sausages (thick)	7-8	turkey (cooked)	6-7
sirloin	7-9	<b>seafood – steaks</b> (25mm)	
T-Bone	8-9	halibut, salmon, swordfish, tuna	6-9
<b>fruit</b>		<b>seafood – fillets</b> (12mm)	
apple, halve/slice	6-8	red snapper, salmon, sea bass	3-5
bananas, slice lengthwise	3-4	<b>seafood</b>	
nectarines/peaches, halve/slice	3-5	kebabs, 25mm cube	4-6
pineapple, slice	3-7	langoustines, prawns	1-2
<b>pork</b>		scallops	4-6
burger, 50g, fresh	5-6	<b>snacks</b>	
burger, 100g, fresh	7-8	calzone	8-9
chop, 12mm	5-6	hot dogs	2-3
gammon steak	5-6	quesadillas	2-3
kebabs, 25mm cube	7-8	tacos, meat filling	6-8
sausages (thin)	5-6	<b>vegetables</b>	
sausages (thick)	7-8	asparagus	3-4
tenderloin, 12mm	4-6	carrots, sliced	5-7
<b>chicken/turkey</b>		aubergine, slice/cube	8-9
chicken breast pieces	5-7	onions, thin slice	5-6
burger, 50g, fresh	4	peppers, thin slice	6-8
burger, 100g, fresh	5	peppers, grill then skin	2-3
kebabs, 25mm cube	7-8	whole peppers brushed with oil	8
thighs (chicken)	5-7	potatoes, slice/cube	7-9
turkey breast, thin sliced	3-4	squash, slice/cube	6-8

## a few recipes to get you started

- Preheat the grill before cooking.
- When times are shown as a range (e.g. 5-7 minutes), we suggest you cook for the minimum time, then start checking the food for readiness.

### contact grilling

#### sausage and herb stuffed pork

- 250g/½lb low-fat sausage, uncooked
- ½ cup fresh breadcrumbs
- 2 tbsp fresh parsley
- ½ tsp thyme
- ½ tsp marjoram
- 1 tsp fresh ground black pepper
- 2 whole pork tenderloins (fillets)
- 8 cocktail sticks, soaked in water then patted dry

Remove the sausage skins. Mix the sausagemeat, marjoram, thyme, parsley, and pepper in a bowl. Cut each tenderloin in two, then cut a slit sideways into each piece to make a pocket. Stuff the pockets with the mixture, and fasten the edges with cocktail sticks. Grill till the pork and stuffing are cooked through (6-8 minutes).

serves a family of 4



#### chicken tandoori with yogurt-based marinade

- 2 boneless, skinless chicken breasts
- 200-250g carton plain low-fat yogurt
- 1 tbsp lemon juice
- 2 tsp paprika
- 2 garlic cloves, minced
- ½ tsp ground ginger
- ½ tsp cumin
- ½ tsp cayenne pepper
- ½ tsp cinnamon

Use a lidded casserole dish big enough to hold the chicken and the marinade. Mix the yogurt, lemon juice, paprika, garlic, ginger, cumin, cayenne and cinnamon in the dish. Cut each chicken breast into two, add them to the dish, and turn till they're well coated. Cover and refrigerate for 1-8 hours, turning at least every hour. Grill the chicken till it's cooked through (5-7 minutes). Discard the marinade.

serves a family of 4



#### smoked mackerel panini with tomatoes and crème fraiche

serves 1

- 2 small cooked smoked mackerel fillets
- 2 thick slices wholegrain/wholewheat
- 4 cherry tomatoes, halved
- 1 large handful watercress

#### dressing

- 2 tbsp reduced fat crème fraiche
- ½ tsp lemon zest, grated
- squeeze lemon juice
- 1 tsp black pepper

Mix the dressing ingredients and refrigerate. Flake the mackerel on a slice of bread, top with tomatoes and watercress, then the other slice, cook for 2-3 minutes, add the dressing, and serve.



## Mediterranean beef and vegetable grill

serves a family of 4

- 500g/1lb hindquarter flank steak
- 1 small courgette, cut into 8 pieces
- 1 small tomato, cut into 8 pieces
- 1 small onion, cut into 8 pieces
- 1 green pepper, cut into 8 pieces
- 1 tbsp balsamic vinegar
- 1 tsp fresh ground black pepper
- 1 tsp garlic granules

8 wooden skewers, soaked in water then patted dry  
Mix the vinegar, pepper and garlic granules in a bowl. Freeze the steak for 30 minutes, then cut it into thin strips, across the grain. Discard any fat. Thread the steak on 4 skewers, and the tomato and vegetables on the other 4. Grill the steak skewers for 4 minutes, then add the vegetable skewers to the grill. Sprinkle the skewers with the vinegar, pepper and garlic mixture, and grill for 3-4 minutes more.



## herbed chicken and mushroom kebabs

serves 4

- 2 boneless, skinless chicken breasts
- 500g/1lb fresh whole mushrooms
- 1 tsp dried rosemary
- 1 tbsp dried parsley
- ½ tsp dried thyme
- ¼ cup lemon juice
- 2 tbsp white vinegar
- ½ cup nonfat chicken broth
- 1 tsp black pepper

8 wooden skewers, soaked in water then patted dry  
Use a lidded casserole dish big enough to hold the chicken, mushrooms and marinade. Mix the rosemary, parsley, thyme, juice, vinegar, broth, salt and pepper in the dish. Cut the chicken into 25mm/1" cubes, add to the dish, and turn till they're well coated. Add the mushrooms, and turn gently. Cover and refrigerate for 4-12 hours, turning occasionally. Thread the chicken and mushrooms on the skewers, and grill till cooked through (5-7 minutes). Discard the marinade.



## healthy pizza pitta pockets

serves 2

- 2 slices lean ham or turkey (cooked)
- 50g/1½oz reduced fat mozzarella
- 2 wholemeal pitta breads
- 2 tomatoes, thinly sliced
- 2 mushrooms, thinly sliced
- ¼ small onion, thinly sliced
- 1 tbsp sweetcorn
- ¼ green pepper, diced
- 1 tbsp tomato purée
- 1 tsp olive oil
- 1 tsp dried mixed herbs

Slit open each pitta bread to form pockets, and spread the tomato purée inside each pocket. Cut the ham/turkey into strips, turn them in a bowl with the other ingredients, rest for half an hour to rehydrate the herbs, then fill the pitta pockets and grill for 3-5 minutes.



## **goujons of fish with carrot sticks and sweet potato wedges**

**serves 2**

- 1 large tuna, cod or salmon steak
- 1 medium carrot
- 1 small sweet potato
- 25g/1oz wholemeal flour
- 1 egg white
- breadcrumbs from 1 slice of wholemeal bread
- 1 tsp white pepper
- ½ tsp medium curry powder (optional)
- 1 tsp clear honey
- 1 tsp olive oil
- 1 tsp paprika



Put the olive oil in a bowl. Cut the sweet potato into thin wedges. Toss the wedges in the bowl to coat them with oil, then put them on a plate.

Stir the paprika and honey into the bowl. Cut the carrot into sticks about the same width as the thick ends of the potato wedges, and toss them in the bowl to coat them. Put the wedges and sticks on the grill, and cook for 4 minutes.

Mix the flour, curry powder and pepper on a plate. Put the egg white on another plate, and mix with a fork. Put the breadcrumbs on a third plate.

Cut the fish into goujons (fingers), and dip the fish goujons into the seasoned flour, then into the egg white, then the breadcrumbs.

When the wedges and sticks have cooked for 4 minutes, add the goujons to the grill, and cook for another 3-4 minutes, or till the breadcrumbs turn golden.

## **warm Asian-style noodle and tofu salad**

**serves 2**

- 60g/2oz buckwheat or soba noodles
- 250g/8oz pre-cooked tofu, drained and cubed
- 1 carrot, peeled and grated into long strips
- 1 head pak choi, shredded
- ½ courgette, cut into long strips
- ½ red onion, cut into strips
- small handful fresh coriander leaves, torn

### **marinade**

- 1 garlic clove, crushed
- 1 red chilli, de-seeded and finely chopped
- 2 tbsp reduced sodium soy sauce
- 1 tsp sweet chilli dipping sauce
- 1 tsp sesame oil
- juice of ½ lime



Combine the marinade ingredients in a bowl, add the tofu, and refrigerate overnight.

Boil two litres of water in a large pan, add the noodles, bring back to the boil, and boil for 10 minutes, drain, transfer to a serving dish, and keep warm.

Grill the marinated tofu till golden brown (2-3 minutes), then remove and set aside.

Grill the carrot, courgette, pak choi and onion for 30-60 seconds to wilt them.

Lay the wilted vegetables on the noodles, top with the grilled tofu, and garnish with the coriander and a squeeze of lime juice.

## creamy cheesy chicken parcels with hidden green stuff

serves 2

- 1 lean skinless chicken breast
- 2 flour tortilla wraps
- 75-100g/2½-3oz reduced fat cream cheese
- 100g/3oz fresh baby spinach leaves
- 1 tsp mustard powder
- 1 tsp grated nutmeg
- 1 tsp pepper

Grill the chicken till it's cooked through (6-8 minutes). Remove it from the grill, let it cool, and cut it into strips. Wash and dry the spinach, wilt the leaves on the grill for 20-30 seconds, remove, and dry with kitchen paper. Mix the cream cheese and spinach in a bowl, then fold in the chicken strips.

Spoon the mixture into the centre of the tortilla wraps, fold one end of each wrap over, roll the wraps up, and warm the filled wraps on the grill for 2-3 minutes.



## wholegrain panini with feta, red onions and red pepper

serves 1

- 2 thick slices wholegrain or wholewheat bread
- 50g reduced fat feta cheese
- ½ red onion, cut into thin strips
- ½ red pepper, cut into strips
- 2 tbsp balsamic vinegar
- ½ tsp fresh ground black pepper

Mix the onion, red pepper, balsamic vinegar and black pepper in a bowl. Spoon the mixture on to the grill, cook till softened (1-2 minutes), and lay it on a slice of bread. Tear the feta, sprinkle over the mixture, and top with the other slice of bread. Clean the grill, then grill the panini for 2-3 minutes. Serve with a watercress and tomato salad.



## quick and easy grilled bananas

serves 2

- 2 bananas, peeled
- 2 tbsp walnuts, finely chopped
- 2 tbsp sugar
- ½ tsp cinnamon

Mix the walnuts, sugar and cinnamon in a bowl. Split the bananas lengthwise, then across their width. Lay the bananas on the grill, flat sides uppermost, and spoon the mixture on top of them. Grill till the bananas are warm and the cinnamon and walnuts are slightly glazed (3-4 minutes).



## grilled strawberry maple shortcake

serves 4

- 1 low-fat shortcake, cut into 8 slices
- ¼ cup maple syrup
- 2 cups fresh strawberries, cleaned and sliced
- 1 cup non-fat whipped cream topping

Lay the shortcake pieces on the grill, brush with maple syrup, and grill for 3-5 minutes. Remove, top with strawberry slices and whipped cream topping.



## vanilla fruit kebabs with a quick creamy dip

serves 4

- ½ fresh pineapple or a tin of pineapple chunks
- 1 small orange
- 2 bananas
- 2 peaches or nectarines
- 1 tsp brown sugar
- 4 tbsp orange juice
- 2 small tubs fruit fromage frais
- 1 tsp vanilla extract

8 wooden skewers, soaked in water then patted dry

Cut the fruit into chunks and marinade for 10 minutes in the orange juice, brown sugar, and half the vanilla extract.

Thread the marinated fruit chunks on the skewers, and grill for 4-6 minutes.

Mix the fromage frais with the other half of the vanilla extract as a dip for the kebabs.



## the original burger

serves 4

- 500g/1lb lean minced beef
- 1 tbsp Worcestershire sauce
- 1 tsp black pepper
- 1 red onion
- 4 wholegrain burger buns
- tomato, lettuce, dill pickles, etc. to garnish

Combine the mince, Worcestershire sauce and pepper, and shape into 4 burgers.

Slice the onion into 12mm/½" thick slices.

Grill the burgers for 4 minutes, top each with an onion slice, then grill for 3-4 minutes more.

Serve the burgers on the buns with your choice of garnish (tomato, lettuce, dill pickles, etc.).



## Santa Fé veggie-burger

serves 4

- 1 cup steamed white rice
- ½ cup of canned corn kernels
- 1 green pepper, seeded
- 1 large white onion
- 1 tsp fresh ground black pepper
- 1 tsp lemon juice
- 1 tsp chilli powder
- 4 wholegrain hamburger buns
- non-fat cooking spray

Use a blender or food processor to process the rice, corn, green pepper, onion, pepper, juice and chilli powder to a coarse, mealy texture.

Shape the mixture into 4 burgers and refrigerate for 2 hours.

Spray the grill lightly with non-fat cooking spray, grill the burgers till well browned (6-7 minutes), then serve in the buns.



## **raclette grilling**

### **triple cheese and garlic mushroom melt**

- 1 mini-baguette, crusty roll or ciabatta
- 3-4 button mushrooms (thinly sliced)
- 25g grated mature cheddar
- 25g grated mozzarella
- 25g grated gruyere or emmental
- 1 clove garlic (crushed)
- olive oil (or flavoured oil e.g. basil, chilli)
- small handful flat leaf parsley (chopped)

Split the bread, drizzle the cut sides with the oil, then smear with the crushed garlic.

On one piece, put the three cheeses, then the parsley, then the mushrooms.

Put the other piece on top, then grill for 3-4 minutes, till the cheese has melted.

### **granary bread panini with smoky bacon, Stilton and toasted walnuts**

- 2 thick slices of granary, wholemeal, or walnut bread)
- 2 rashers smoky bacon
- 50g crumbled Stilton
- 1 tsp olive oil or butter
- 2-4 walnuts
- small handful rocket leaves to serve

Roast the walnuts on a hot grill for 1-2 minutes, cool slightly, then chop roughly.

Cook the bacon on the grill for 2-4 minutes till crisp, then dry on kitchen towel.

Drizzle each bread slice with olive oil or spread with butter, top one slice with Stilton, bacon and walnuts, put the other slice on top, and grill for 3 minutes.

Serve with rocket leaves.

### **grilled steak sandwich with horseradish, baby tomatoes and watercress**

- 1 sirloin steak
- 2 thick slices crusty bread
- 2-3 sliced baby plum tomatoes
- 2 tsp horseradish sauce
- small handful watercress
- black pepper

Cook the sirloin steak on the hot grill for 2-3 minutes till cooked through, remove and rest on kitchen paper for 5 minutes.

Spread horseradish sauce on both slices of bread, top one slice with the steak, tomatoes and watercress, season with black pepper, put the other slice on top, and grill for 2 minutes, till the bread is warmed through and crispy.

### **toasted bagel with garlic mayonnaise tuna, peppers and sweetcorn**

- 2 bagels
- 1 tin tuna (drained)
- 2 tbsp garlic mayonnaise
- 2 tbsp chopped red pepper
- 2 tbsp chopped green pepper
- 1 tbsp sweetcorn
- white pepper

Split the bagels and lay them split side down on the hot grill for 1-2 minutes.

Mix the tuna, mayonnaise, peppers and sweetcorn, and season with white pepper.

Make sandwiches of the bagels and tuna mixture, then grill for 2-3 minutes.

## connection

The product must be earthed. It has a 13A BS1362 fuse in a 13A BS1363 plug. To replace the plug, fit the green/yellow wire to ⊕ or E, the blue wire to N, and the brown wire to L. Fit the cord grip. If in doubt, call an electrician. Don't use a non-rewireable plug unless the fuse cover is in place. If you remove the plug, dispose of it.

## wheelie bin symbol

To avoid environmental and health problems due to hazardous substances in electrical and electronic goods, appliances marked with this symbol mustn't be disposed of with unsorted municipal waste, but recovered, reused, or recycled.

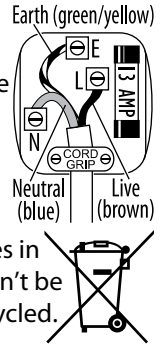

## service

If you ring Customer Service, please have the **Model No.** to hand, as we won't be able to help you without it. It's on the rating plate (usually underneath the product).

The product isn't user-serviceable. If it's not working, read the instructions, check the plug fuse and main fuse/circuit breaker. If it's still not working, consult your retailer. If that doesn't solve the problem:

Pack carefully, with a note of your name, address, day phone number, and what's wrong. If under guarantee, say where and when purchased, and include proof of purchase (till receipt). Send it to Customer Returns (address below right).

### Customer Service

(correspondence only)  
Salton Europe Ltd  
Failsworth  
Manchester  
M35 0HS

### Customer Returns

Salton Europe Ltd  
Heath Mill Road  
Wombourne  
Wolverhampton  
WV5 8AQ

Customer Service ([service@saltoneurope.com](mailto:service@saltoneurope.com))  
telephone 0845 658 9700 (local rate number)

## guarantee

Defects affecting product functionality appearing within one year of purchase will be corrected by replacement or repair provided the product is used and maintained in accordance with the instructions. Your statutory rights are not affected.

Documentation, packaging, and product specifications may change without notice.

## online

[www.georgeforemangrills.co.uk](http://www.georgeforemangrills.co.uk)